

Wilson Electronics Is 5G Ready

In today's quickly emerging 5G world, our products continue to enhance cell signals for all phones and cellular-connected devices, on all US carrier networks, for the next decade and beyond.

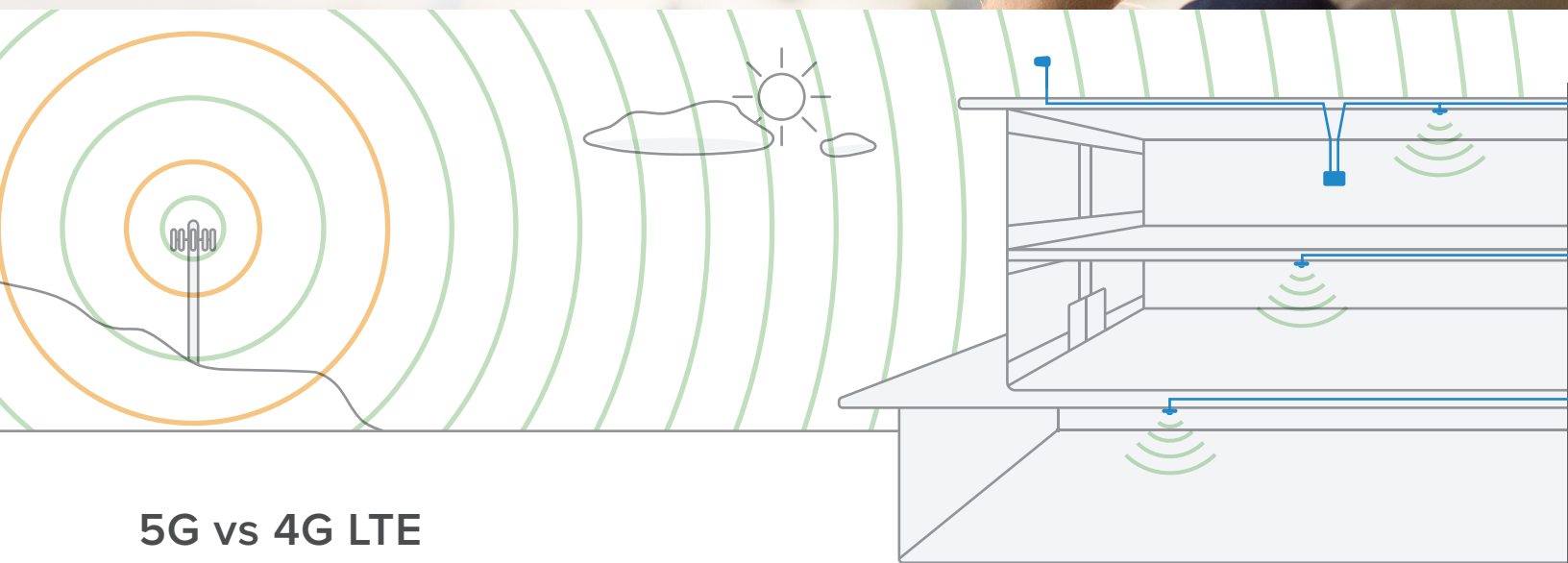

5G vs 4G LTE

5G nodes can transmit data over mmWave frequency at higher data rates but over a smaller area. Using their vast network of existing towers, carriers will fill these coverage gaps with existing 4G LTE signal. Boosters enhance those signals inside buildings.

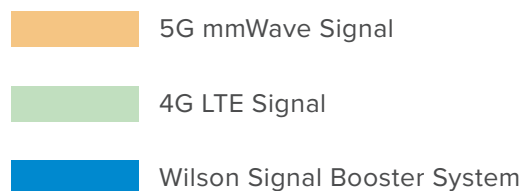

5G Event Timeline

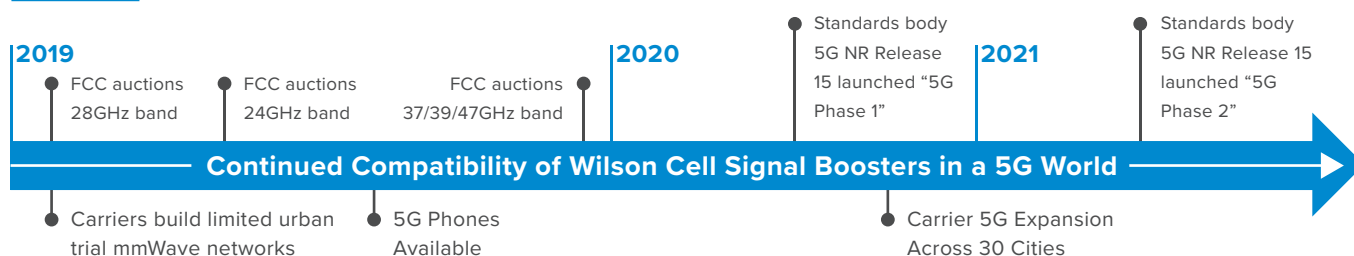



5G FAQs

What is 5G and why is everyone talking about it? Will 5G really matter to me?

A: 5G stands for “5th Generation of cellular standards.” The eagerly anticipated arrival of the 5G network revolves around its performance enhancements over 4G LTE. 5G will provide fiber-like speed over a cellular connection, lower latency for the real-time response necessary for AI and VR applications, and the connection density to meet the massive demand for the IoT. However, it’s important to understand the millimeter-wave signals of 5G drop off faster with distance than lower-frequency signals. Because of its limited range 5G won’t replace 4G LTE but it will provide faster speeds in major metropolitan cities where coverage is more concentrated.

Will 5G make cell signal amplification obsolete?

A: No. As long as natural and man-made barriers to cellular signal exist, cell signal amplification technology will remain crucial to any future cellular network; regardless of latency or speed. Given the higher frequencies of 5G mmWave technology, the physics of going through building materials like concrete, brick, metal, and energy-efficient glass will only worsen—further increasing cell signal decay. The existing 4G LTE network will continue to provide coverage where 5G is limited. Likewise, the need for cell signal amplifiers will continue for any buildings where indoor coverage is limited.

How will 5G affect the need for cell signal amplifier systems?

A: In a 5G world, demand for cell signal amplifier systems will only increase. As 5G frequencies go higher, their ability to penetrate insulated walls and construction materials quickly diminishes. Adapting existing cell signal amplifier system for mid-band 5G frequencies will not be a massive departure from the current infrastructure; only requiring some new hardware components.

Will Wilson amplifiers still work in a 5G world?

A: Yes. Since mobile carriers are planning to use the existing 4G LTE networks to carry the majority of cell service to consumers well into 2030 our current amplifiers will continue to work for years to come. The 5G network is being built alongside today’s 4G LTE network and will rely on the 4G LTE network as part of its failover or redundancy plan.